

# HB

HENRY BRICK COMPANY, INC.

## Brick Shapes

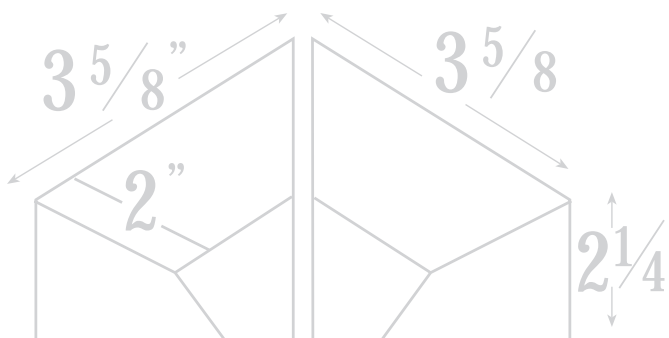

---

## *Table of Contents*

Watertables .....	Page 2
Rowlocks .....	Page 6
Copings .....	Page 9
Treads .....	Page 10
Miscellaneous .....	Page 12
Custom Arches .....	Page 13
Ordering Information .....	Page 15



---

HENRY BRICK COMPANY, INC.  
MANUFACTURERS OF QUALITY FACE BRICK  
[www.henrybrick.com](http://www.henrybrick.com)

Post Office Box 850 • Selma, Alabama 36702-0850

3409 Water Avenue • Selma, Alabama 36703

Telephone 1-334-875-2600 • Toll Free 1-800-548-7576 • Fax 1-334-875-7842

# WATERTABLE

## Splay

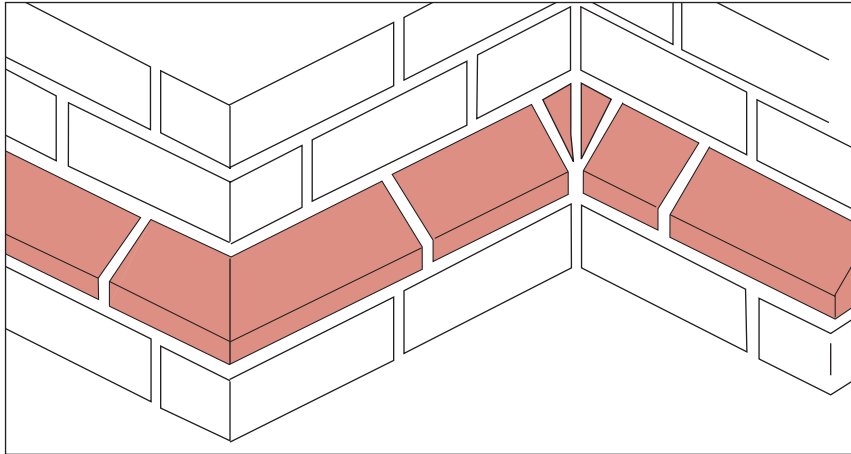

**HEADER  
WS11**

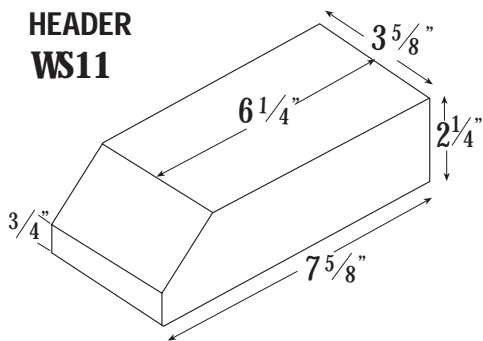

**STRETCHER  
WS16**

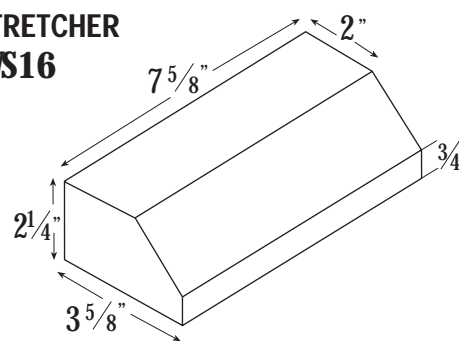

**OUTSIDE CORNER  
WS22**

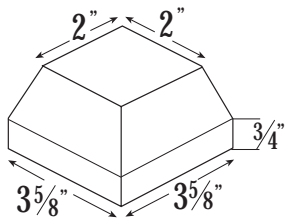

**INSIDE CORNER  
WS23**

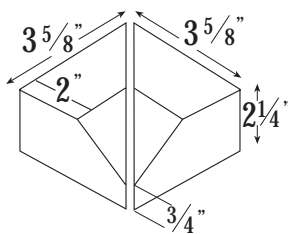

**INSIDE RETURN LEFT  
WS24**

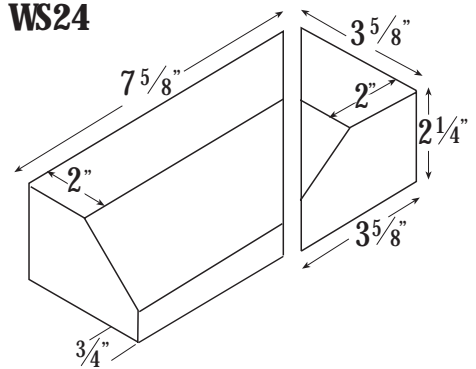

**INSIDE RETURN RIGHT  
WS25**

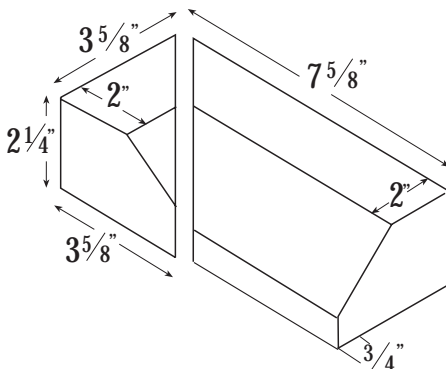

**OUTSIDE RETURN RIGHT  
WS27**

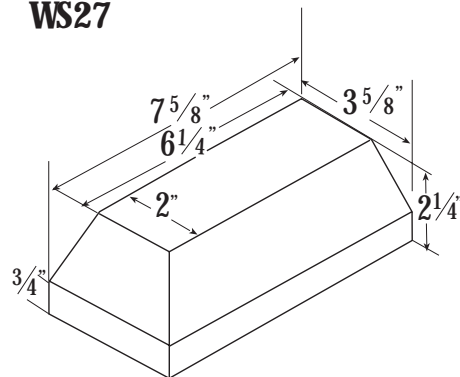

**OUTSIDE RETURN LEFT  
WS28**

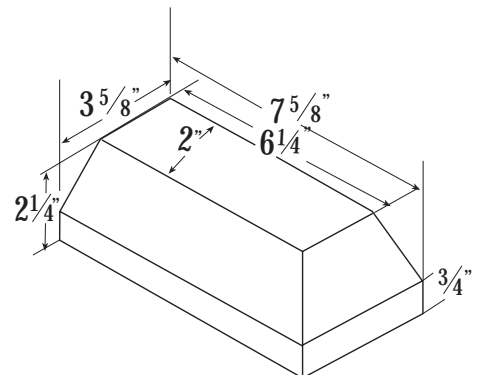

## Bullnose

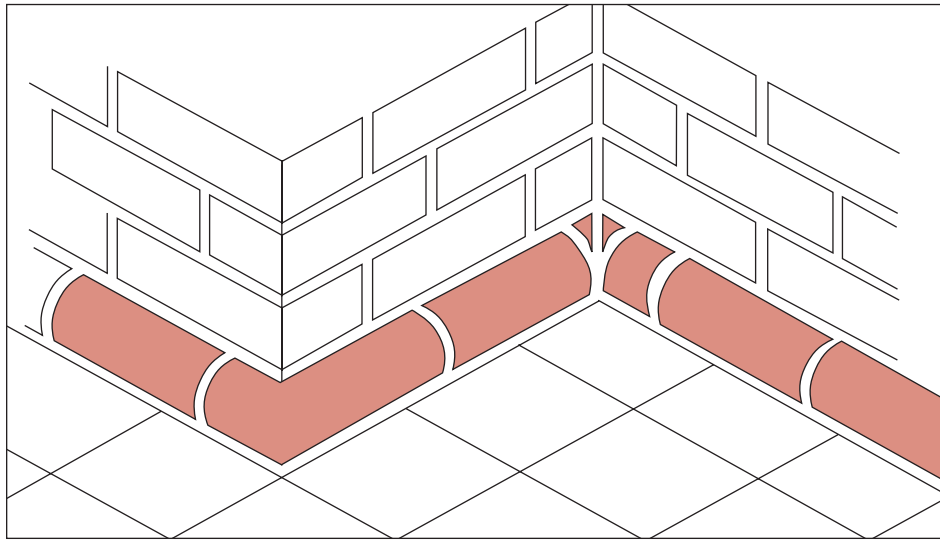

**HEADER  
WB11**

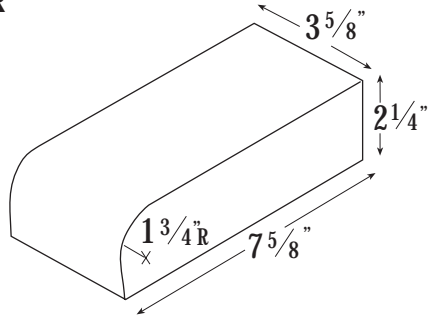

**STRETCHER  
WB16**

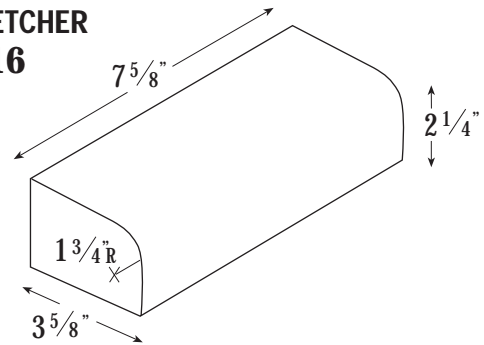

**OUTSIDE CORNER  
WB22**

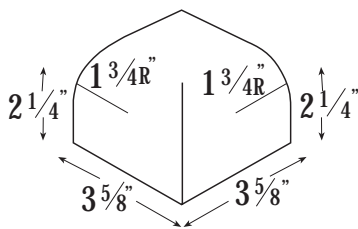

**INSIDE CORNER  
WB23**

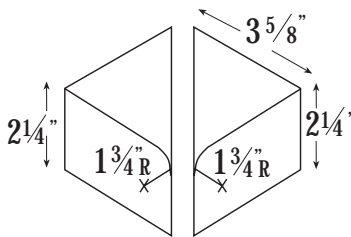

**INSIDE RETURN LEFT  
WB24**

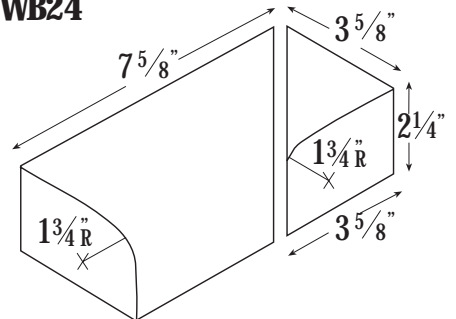

**INSIDE RETURN RIGHT  
WB25**

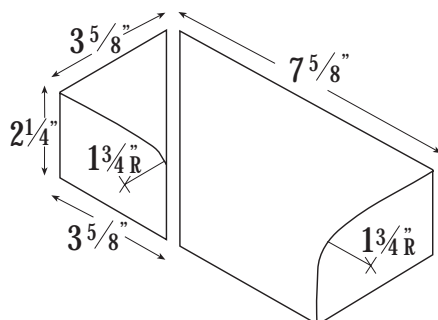

**OUTSIDE RETURN RIGHT  
WB27**

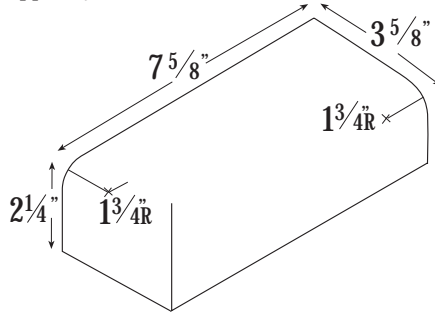

**OUTSIDE RETURN LEFT  
WB28**

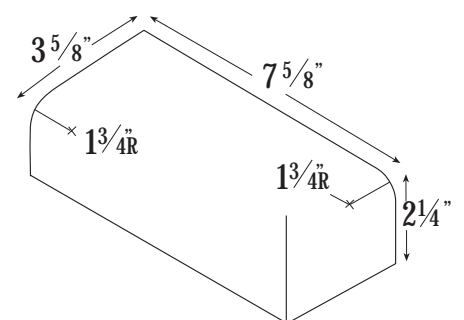

# WATERTABLE

## Cove

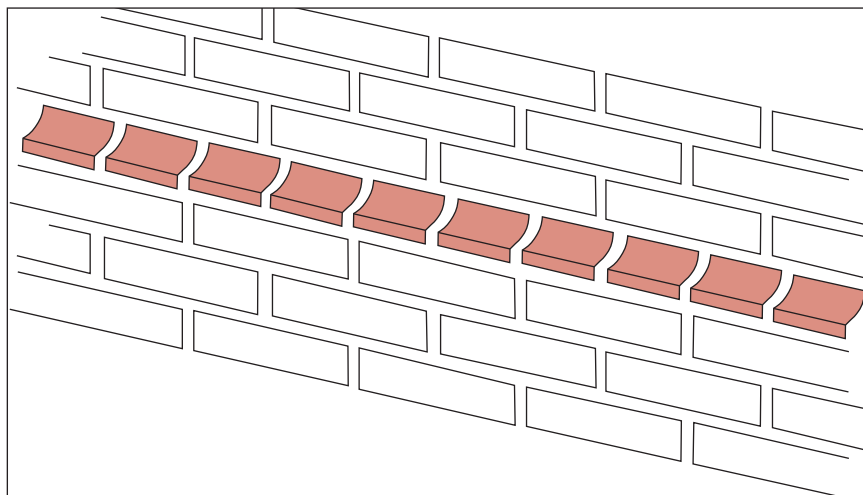

**HEADER  
WC11**

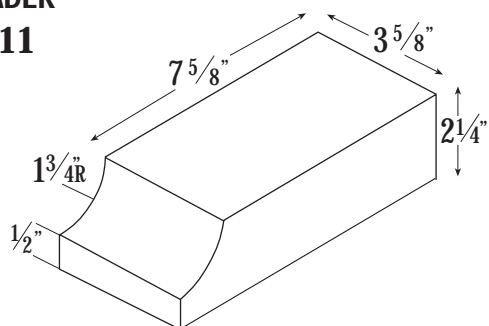

**STRETCHER  
WC16**

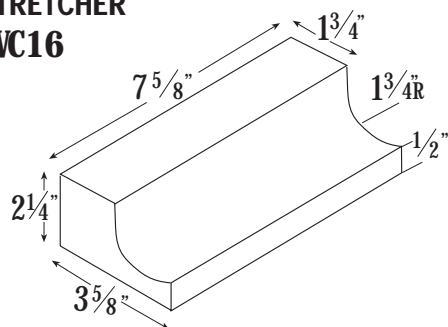

**OUTSIDE CORNER  
WC22**

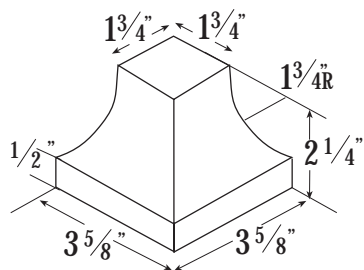

**INSIDE CORNER  
WC23**

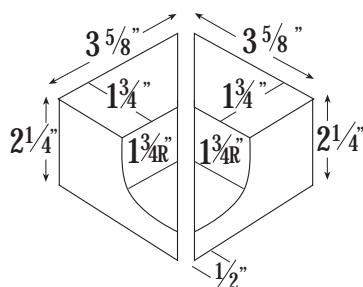

**INSIDE RETURN LEFT  
WC24**

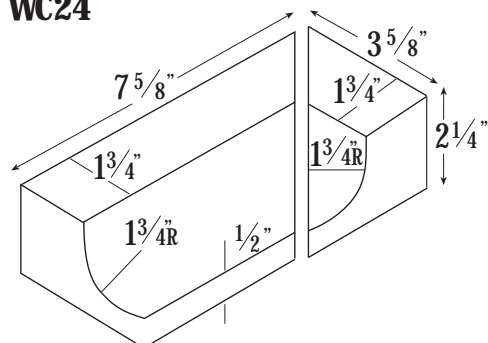

**INSIDE RETURN RIGHT  
WC25**

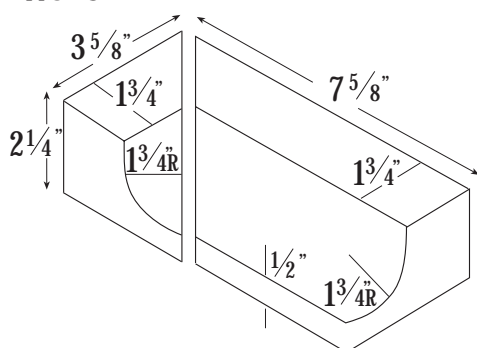

**OUTSIDE RETURN RIGHT  
WC27**

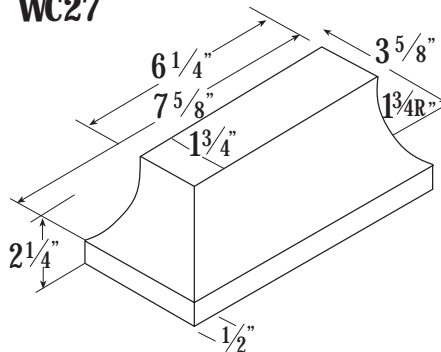

**OUTSIDE RETURN LEFT  
WC28**

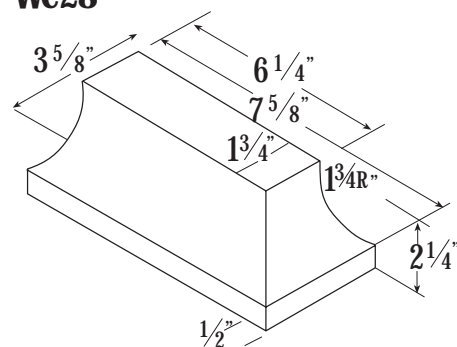

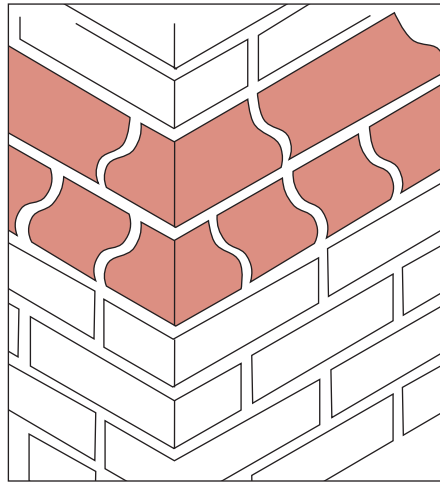

**HEADER  
W011**

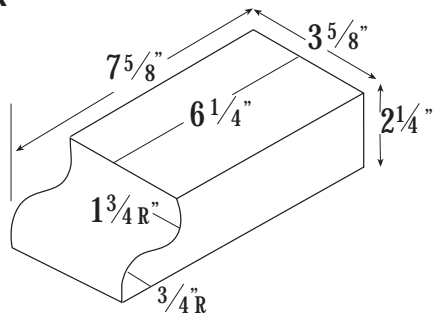

**STRETCHER  
W016**

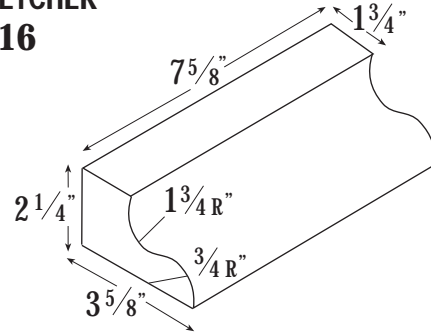

**OUTSIDE CORNER  
W022**

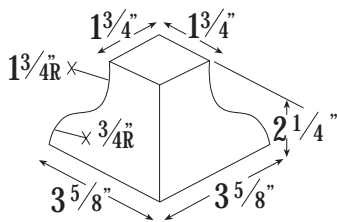

**INSIDE CORNER  
W023**

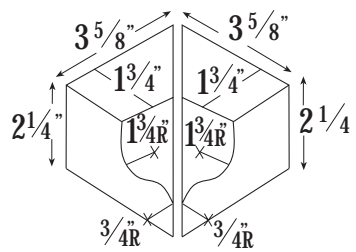

**INSIDE RETURN LEFT  
W024**

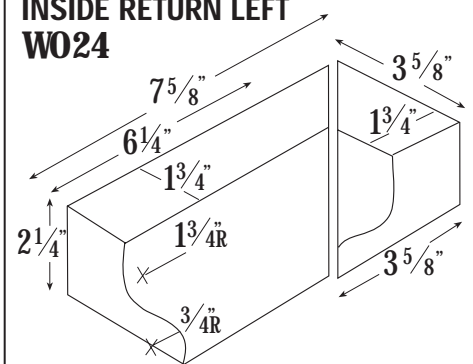

**INSIDE RETURN RIGHT  
W025**

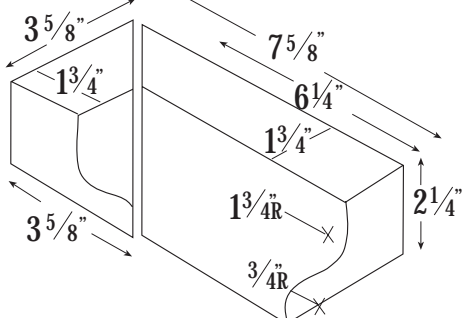

**OUTSIDE RETURN RIGHT  
W027**

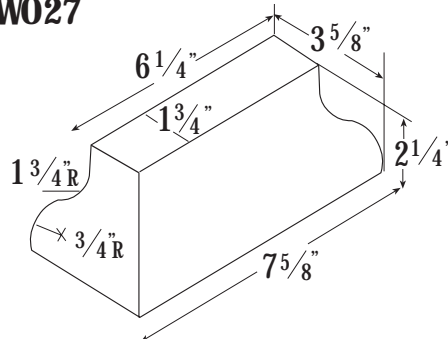

**OUTSIDE RETURN LEFT  
W028**

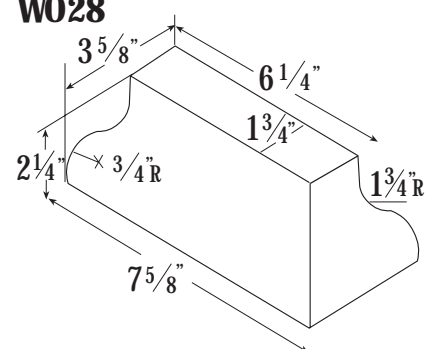

# ROWLOCK

## Ogee

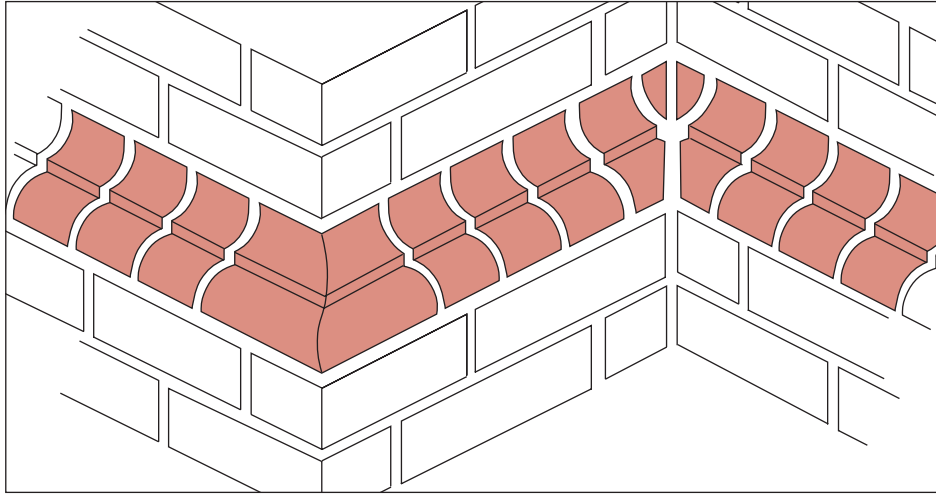

**ROWLOCK  
OGEE  
R011**

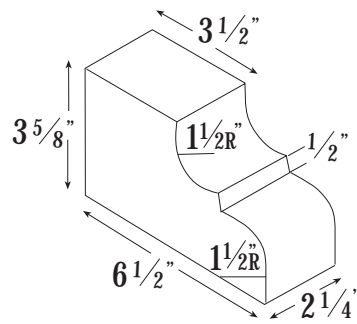

**ROWLOCK OGEE  
OUTSIDE CORNER  
R032**

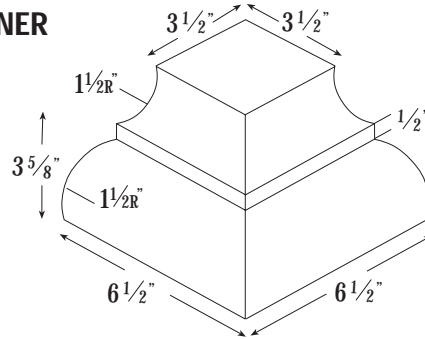

**ROWLOCK OGEE  
INSIDE CORNER  
R033**

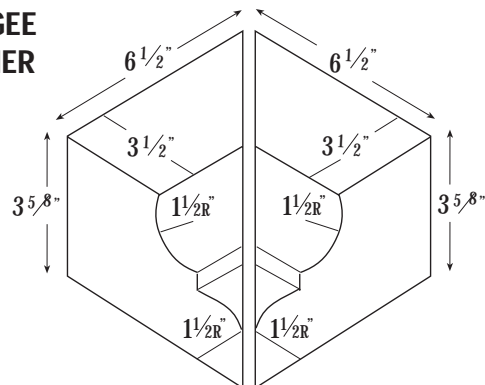

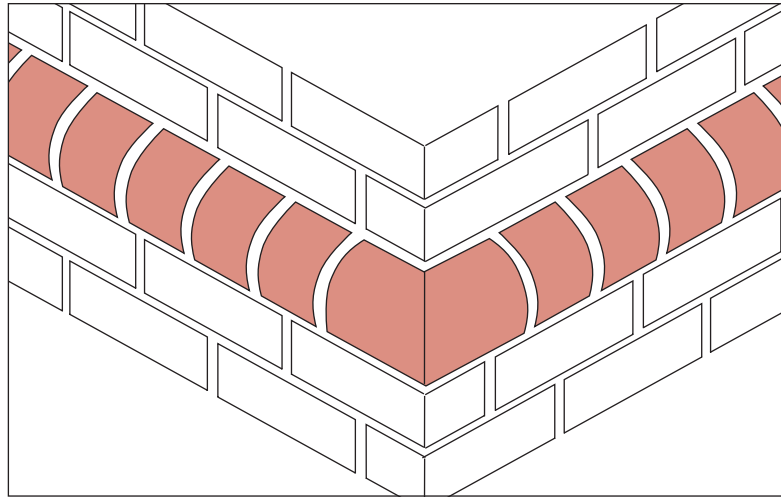

**ROWLOCK  
BULLNOSE  
RB21**

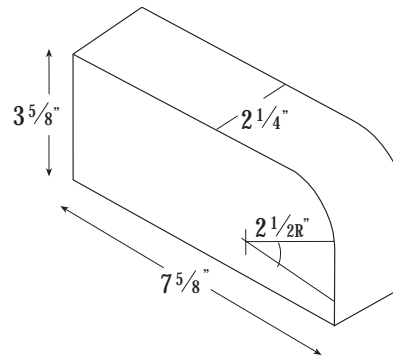

**ROWLOCK  
BULLNOSE  
OUTSIDE CORNER  
RB32**

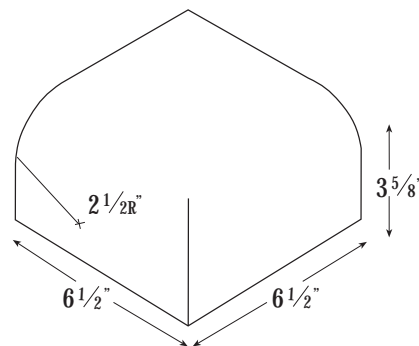

**ROWLOCK  
BULLNOSE  
INSIDE CORNER  
RB33**

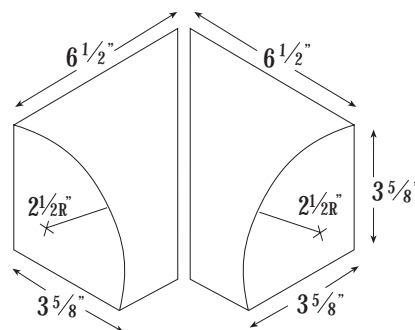



# ROWLOCK

## Cove

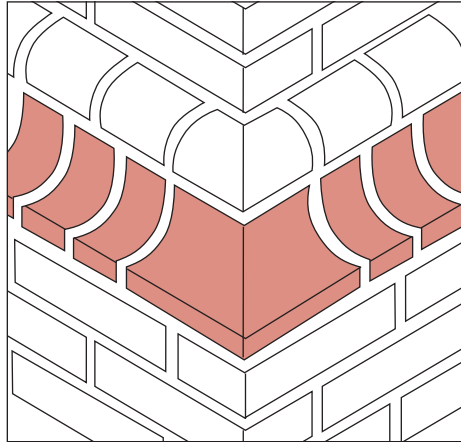

**ROWLOCK COVE  
RC11**

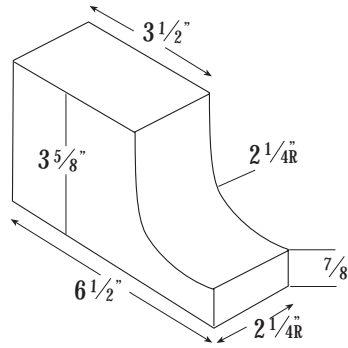

**ROWLOCK COVE  
OUTSIDE CORNER  
RC32**

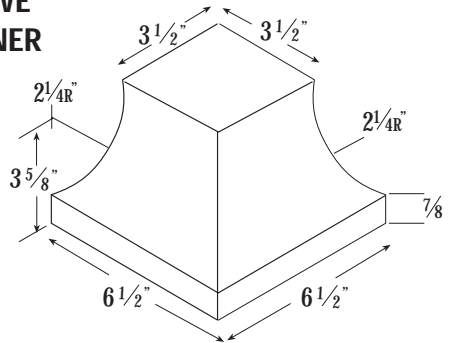

**ROWLOCK COVE  
INSIDE CORNER  
RC33**

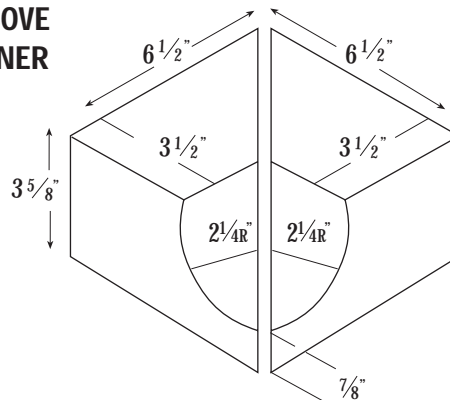

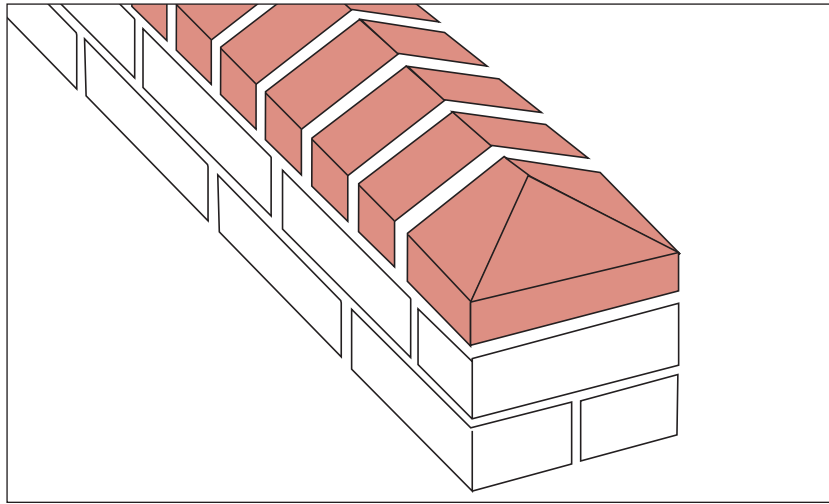

**WALL CAP #1  
CA21**

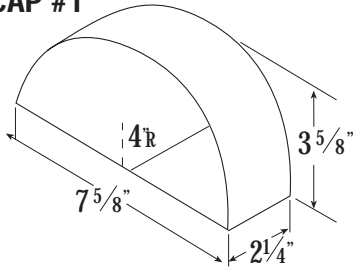

**WALL CAP END #1  
CA82**

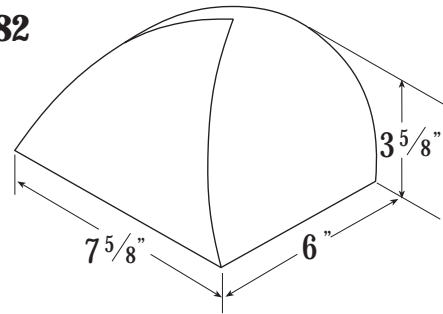

**WALL CAP #2  
CA25**

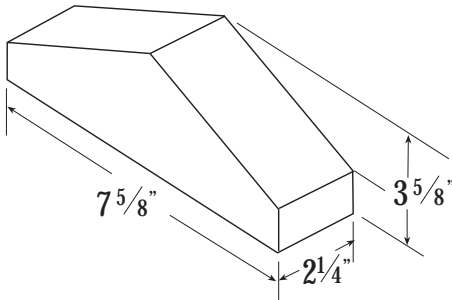

**WALL CAP #3  
CA23**

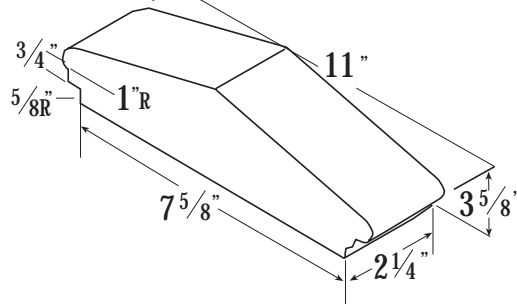

**WALL CAP #4  
CA27**

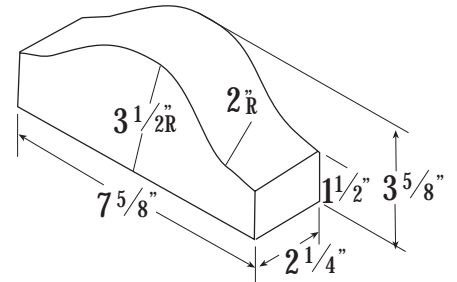

**WALL CAP END #2  
CA86**

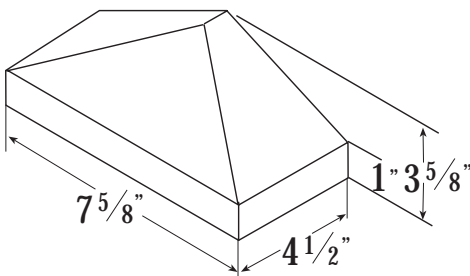

**WALL CAP END #3  
CA84**

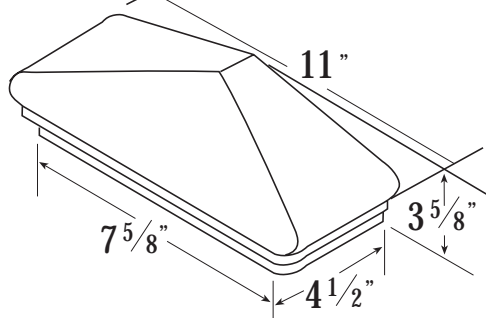

**WALL CAP END #4  
CA88**

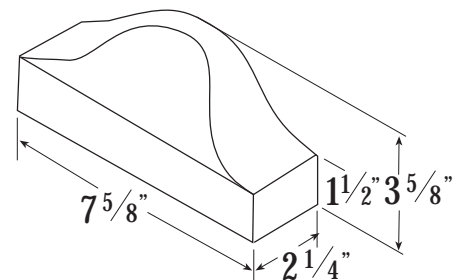

# TREAD

## Rowlock

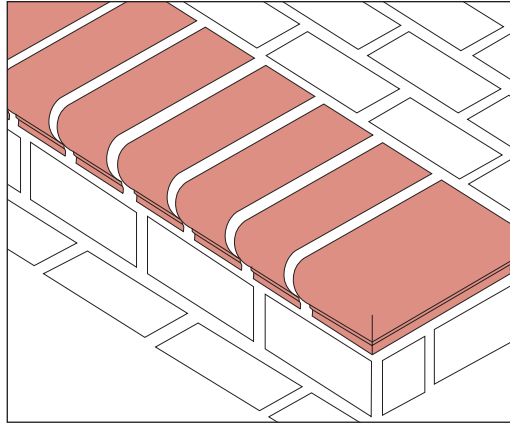

**ROWLOCK TREAD  
TR41**

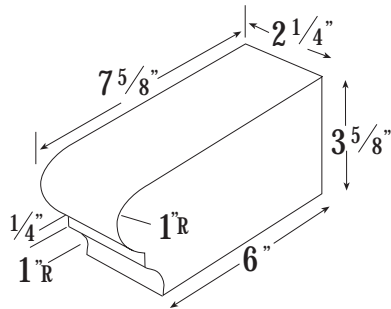

**ROWLOCK TREAD  
OUTSIDE CORNER**

**TR82**

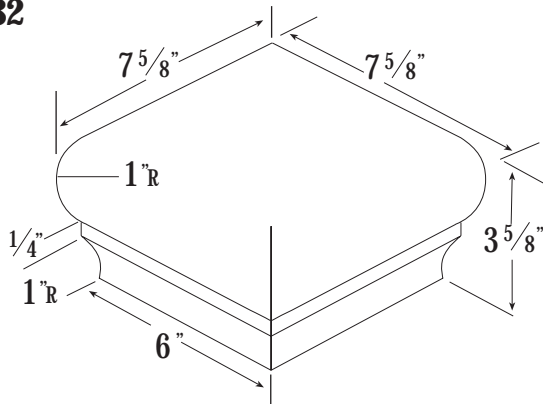

**ROWLOCK TREAD  
INSIDE CORNER**

**TR83**

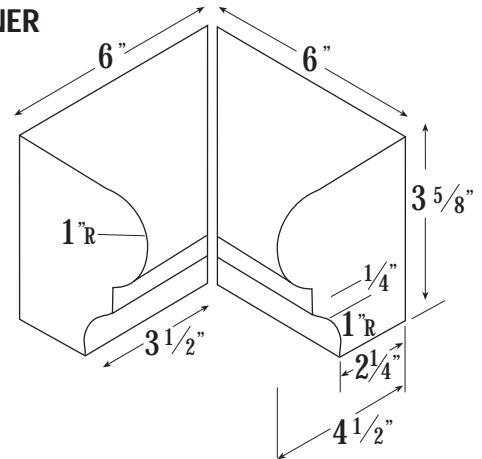

**ROWLOCK TREAD  
RIGHT RETURN**

**TR87**

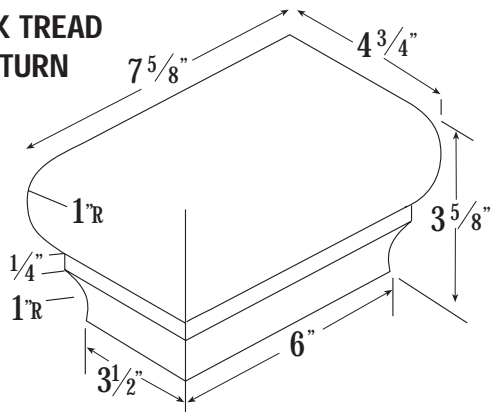

**ROWLOCK TREAD  
LEFT RETURN**

**TR88**

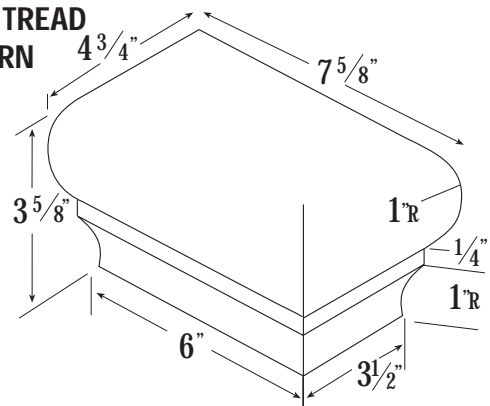

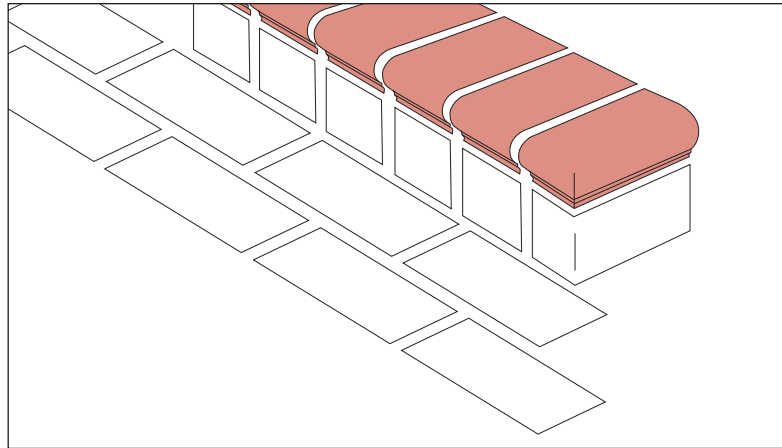

**HEADER TREAD  
TH41**

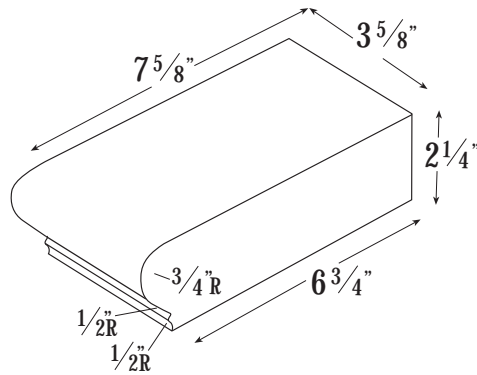

**HEADER TREAD  
OUTSIDE CORNER  
TH82**

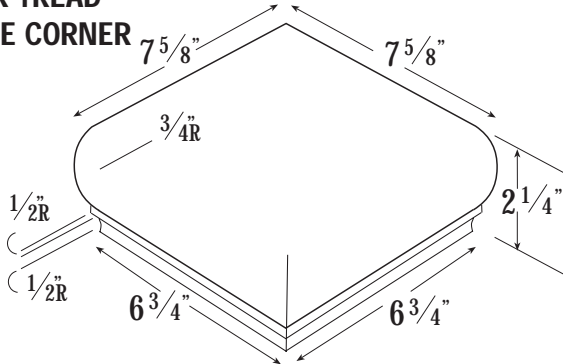

**HEADER TREAD  
INSIDE CORNER  
TH83**

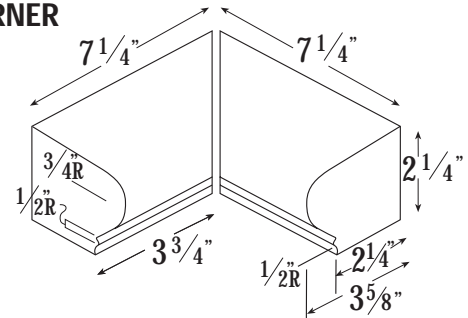

**HEADER TREAD  
RIGHT RETURN  
TH87**

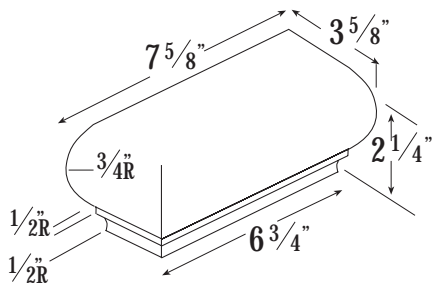

**HEADER TREAD  
LEFT RETURN  
TH88**

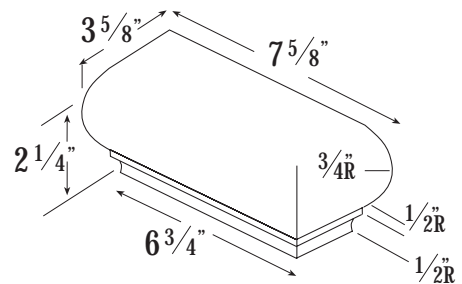

# MISCELLANEOUS

## Bed Coated Solids

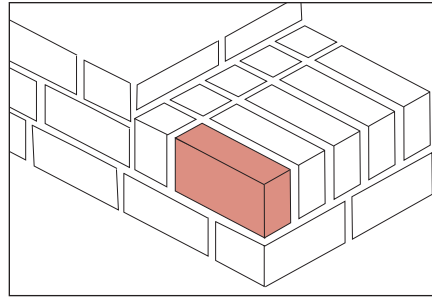

**BED COATED SOLID  
SF01**

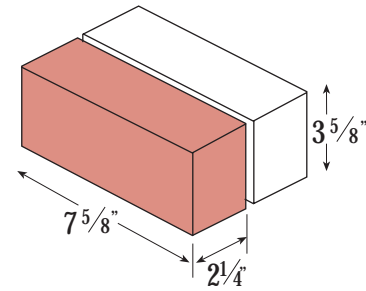

## Radial Brick

*Dimensions may vary  
based on the diameter  
of the column.*

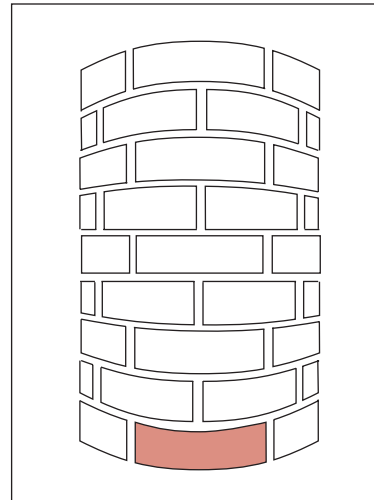
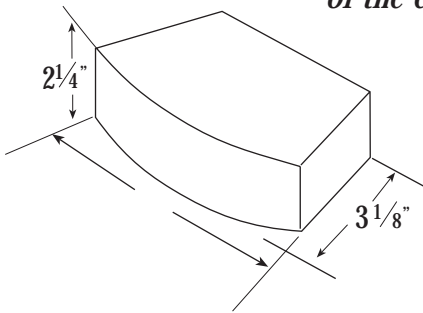

**RADIAL BRICK  
RR 31-18" Column  
RR 32-24" Column**

## Sill Brick

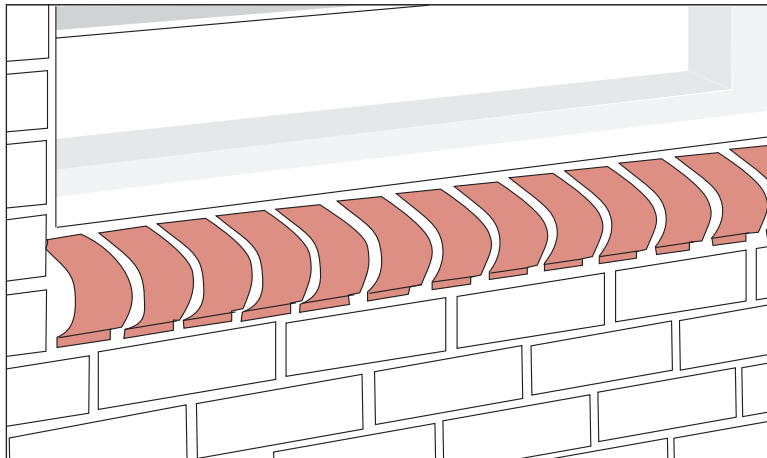

**WINDOW SILL  
SL11**

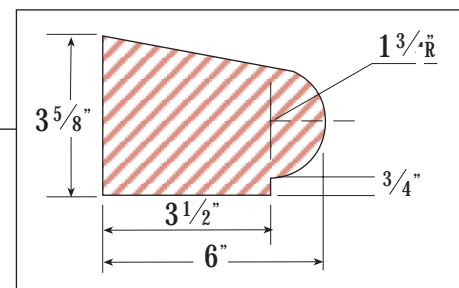
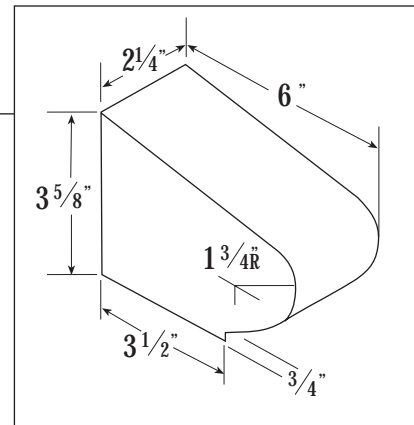

# KEYED JACK ARCH

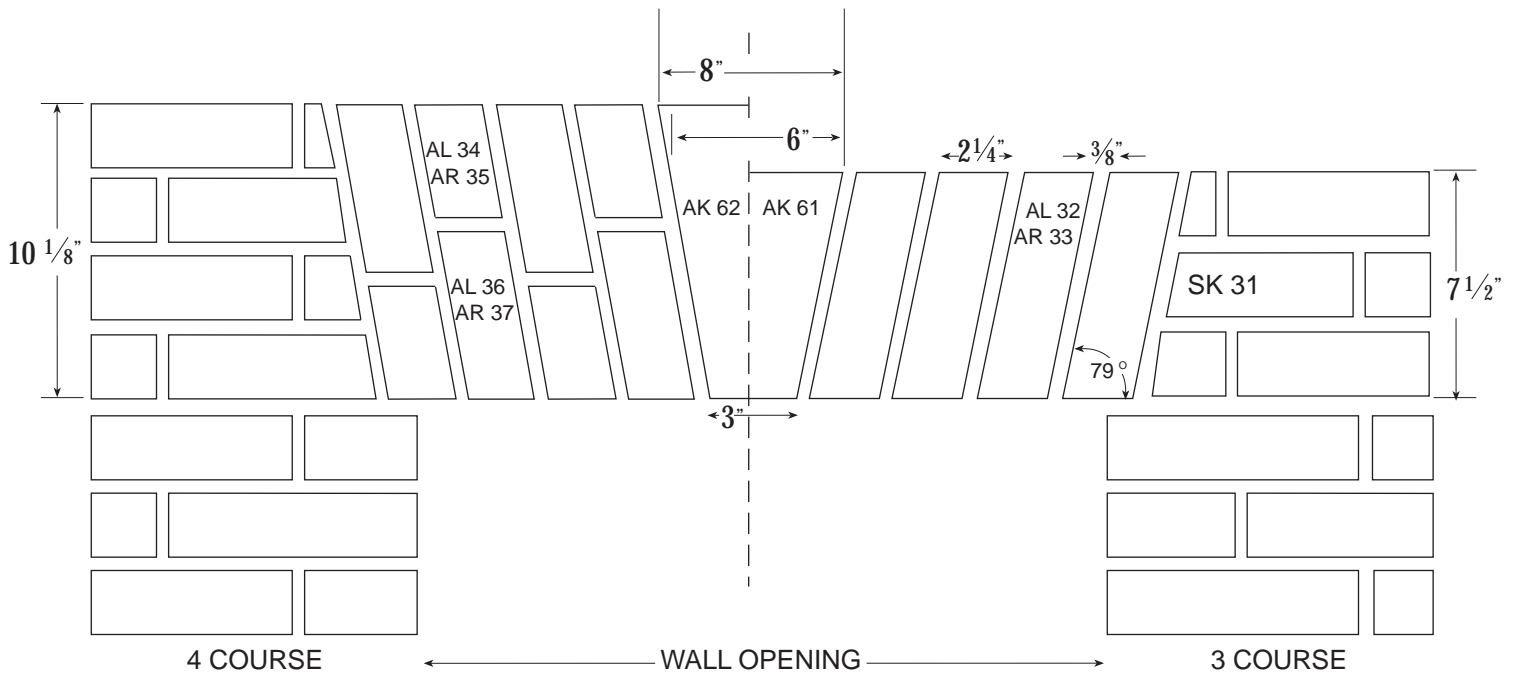

ARCH	WALL OPENING	PIECES REQUIRED
11 piece	27 1/4 to 32 1/2	(1) #AK61, (5) #AL32, (5) #AR33
13 piece	32 1/2 to 38 1/4	(1) #AK61, (6) #AL32, (6) #AR33
15 piece	38 1/4 to 44	(1) #AK61, (7) #AL32, (7) #AR33
17 piece	44 to 49 3/4	(1) #AK61, (8) #AL32, (8) #AR33
19 piece	49 3/4 to 55 1/2	(1) #AK61, (9) #AL32, (9) #AR33
21 piece	55 1/2 to 61 1/4	(1) #AK61, (10) #AL32, (10) #AR33
23 piece	61 1/4 to 67	(1) #AK61, (11) #AL32, (11) #AR33
25 piece	67 to 73 1/4	(1) #AK61, (12) #AL32, (12) #AR33

The above quantities for standard 3 course arch. Skews cut on 79°, 6 required furnished 7 5/8" OA, cut length to suit bond at job site.

# CUSTOM ARCHES

*Any change from style or standard details on all arches shown that are to comply with your design will place the units in a special category and will require detailed drawings to the manufacturer before a quotation can be given.*

The typical standard one-, two-, three-brick arches are calculated with a normal 79-degree skew angle. Radial arches are given in inches of radius. All arches are individually boxed and tagged for location. When ordering arches as shown here, the following information must be submitted for quotation:

- |   |                                       |
|---|---------------------------------------|
| 1. Dimension of full masonry opening.                                   | 4. Number of courses covered by arch. |
| 2. Skew angle (79 degree will be furnished unless specified otherwise). | 5. Type and size of bricks used.      |
| 3. Mortar joint size.   | 6. Style of arch.                     |
|   | 7. Radius, if applicable              |

**JACK ARCH**

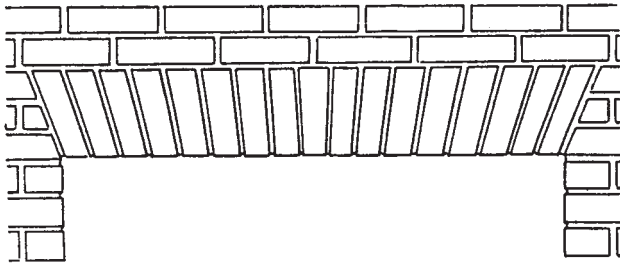

**RADIAL ARCH**

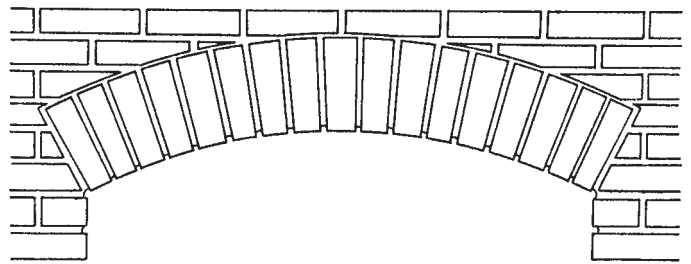

**BONDED JACK ARCH**

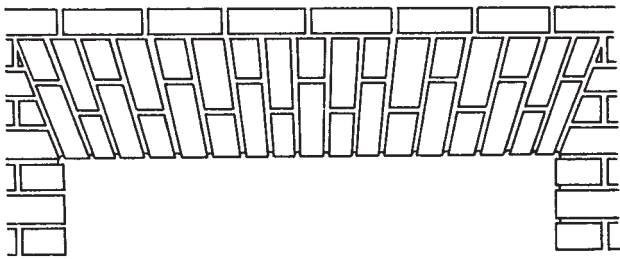

**ELLIPTICAL ARCH**

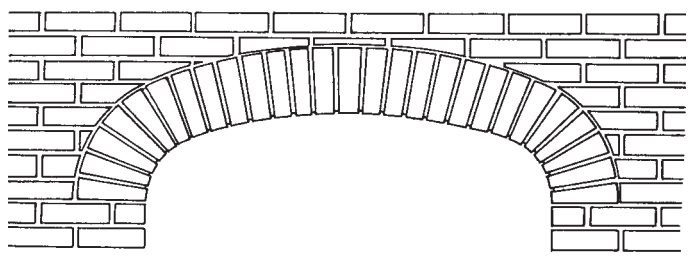

**BONDED RADIAL ARCH**

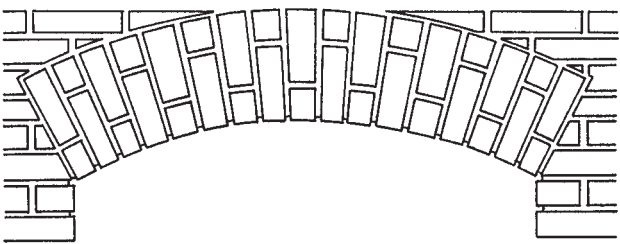

**QUEEN ANNE ARCH**

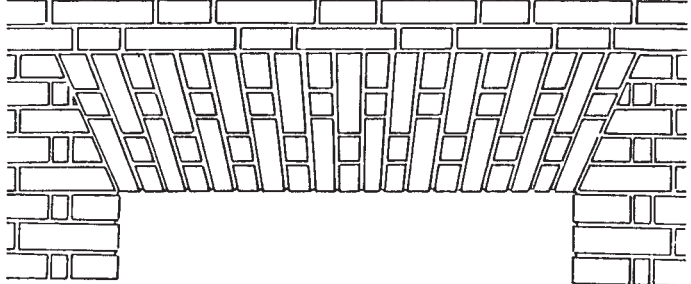

**CIRCULAR ARCH**

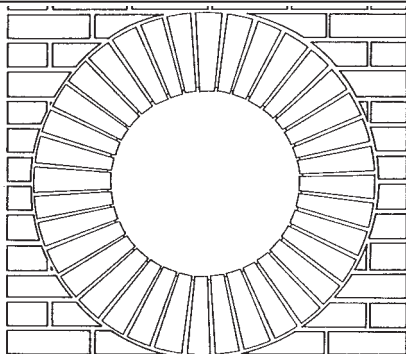

**ROMAN ARCH**

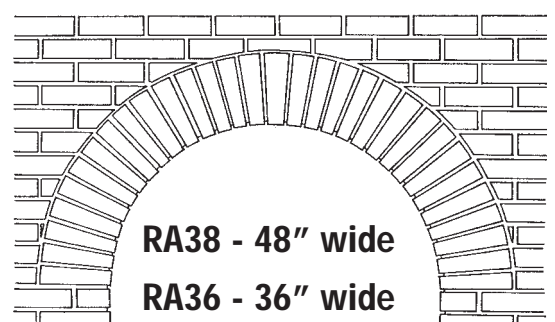

**RA38 - 48" wide**

**RA36 - 36" wide**



HENRY BRICK COMPANY, INC.  
MANUFACTURERS OF QUALITY FACE BRICK  
www.henrybrick.com

## Ordering Special Shapes

Because of the unique nature of special shapes, great care should be taken when ordering. The following steps are very important:

1. Provide accurate drawings.
2. Check for all dimensions.
3. Determine and indicate all surfaces to be finished.
4. Make sure the quantity is correct.
5. Indicate the date and delivery.
6. Provide the name of the architect and general contractor.

### CHECK LIST:

1. Drawings: \_\_\_\_\_
2. Dimensions: \_\_\_\_\_
3. Surfaces: \_\_\_\_\_
4. Quantities: \_\_\_\_\_
5. Delivery Date: \_\_\_\_\_
6. Architect: \_\_\_\_\_
7. General Contractor: \_\_\_\_\_
8. Type of Brick: \_\_\_\_\_

### NOTE:

- All dimensional tolerances will meet ASTM C-216, Type FBS. Angular tolerances will be +4 degrees.
- Orders for special shapes may not be cancelled in whole or in part when shapes are in the process of being manufactured or after they have been completed.
- Small quantities of certain shapes will include a set-up charge in addition to the unit price.
- "Add-on" orders of special shapes which are placed after original quantities have been manufactured are subject to a set-up charge. Color match on certain shades cannot be guaranteed when shapes are ordered after the face brick have been manufactured.
- Delivery schedules for shapes cannot be resolved until after the order is entered and manufacturing schedules are determined.
- Color and texture of certain shapes may vary slightly from that of the face brick.





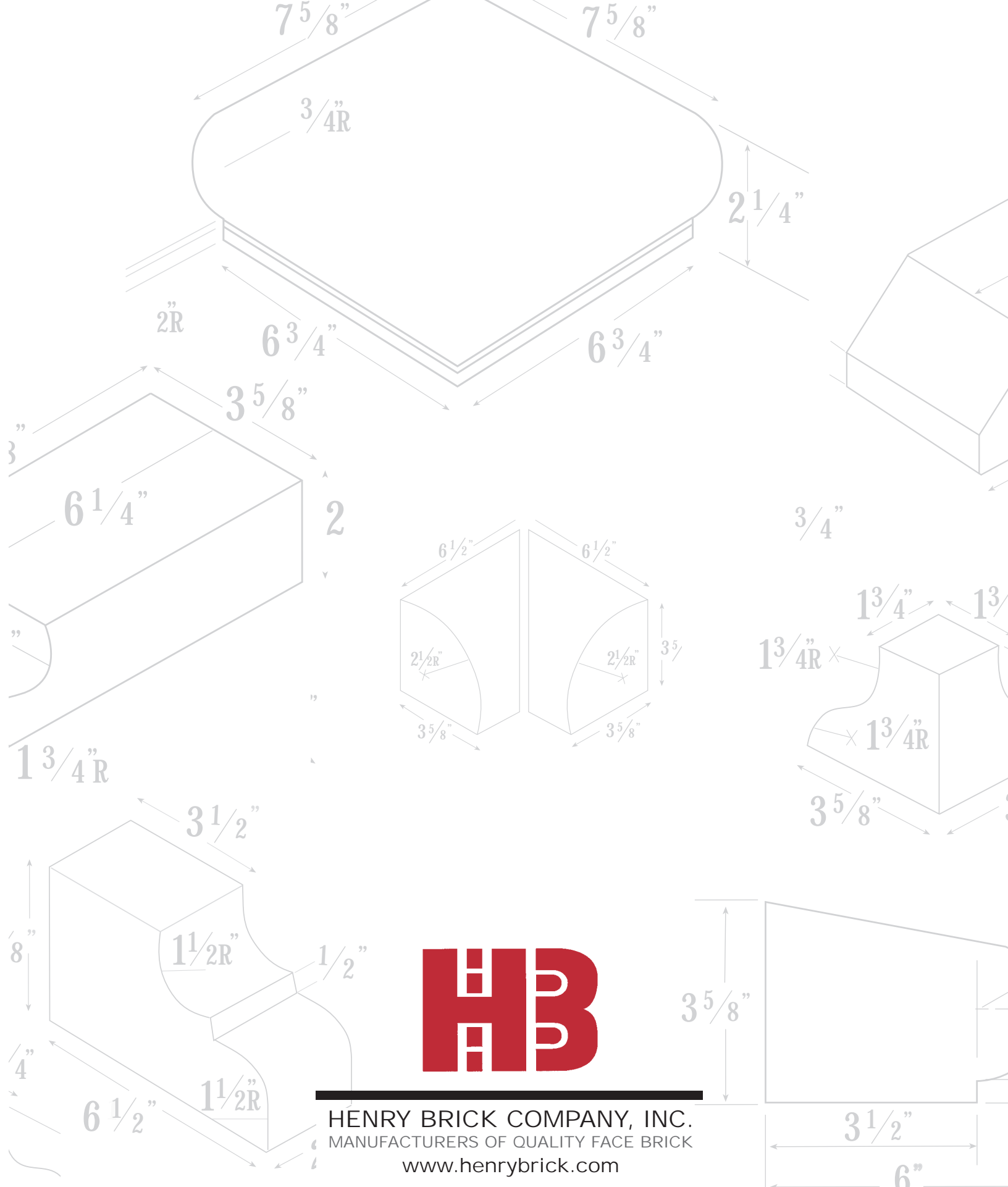

**HENRY BRICK COMPANY, INC.**  
 MANUFACTURERS OF QUALITY FACE BRICK  
[www.henrybrick.com](http://www.henrybrick.com)

Post Office Box 850 • Selma, Alabama 36702-0850

3409 Water Avenue • Selma, Alabama 36703

Telephone 1-334-875-2600 • Toll Free 1-800-548-7576 • Fax 1-334-875-7842